

TEM TRUSS

SINCE 1997



CONCEPTEUR & FABRICANT

CERTIFICATES

ZERTIFIKAT ◆ CERTIFICATE ◆ CERTIFICADO ◆ CERTIFICAT ◆ 認證證書 ◆ CERTIFICATE ◆ CERTIFICADO ◆ CERTIFICAT ◆ 認證證書 ◆ CERTIFICATE

CERTIFICATE

The certification body for lifts and cranes of TÜV SÜD Industrie Service GmbH Westendstraße 199 80686 München - Deutschland

entitles
Truss Aluminium Factory a.s.
Hodolany 1226
77900 Olomouc - Czech Republic

to identify the product specified below with the test mark shown here.



Product: Welded Aluminium Truss
Type: HT44

This certificate is based on test report, order no. 3211133-14.

This certificate is valid until 2025-06-21.

Certificate registration no. 20.06.9812.016.

Filderstadt, 2020-06-22

Achim Janocha
Certification Body „lifts and cranes“



Industrie Service



DVS ZERT
CERTIFICATE
Conformity of the Factory Production Control
2451-CPR-EN1090-2014.1037.003

In compliance with Regulation 305/2011/EU of the European Parliament and of the Council of 9 March 2011, (the Construction Products Regulation) or CPR, this certificate applies to the following construction product:

Construction product	Structural components and kits for aluminium structures to ENCA according to EN 1090-3
Intended use	for load-bearing structures in all types of buildings
CE - marking method	ZA.3.2 and ZA.3.4 acc. to EN 1090-1:2009+A1:2011
Manufacturer	produced by or for Truss Aluminium Factory a.s.
	Hodolany 1226 779 00 Olomouc CZECH REPUBLIC
Manufacturing plant	Truss Aluminium Factory a.s. Hodolany 1226 779 00 Olomouc CZECH REPUBLIC
Confirmation	This certificate attests that all provisions concerning the assessment and verification of constancy of performance (see Annex ZA of the harmonised standard EN 1090-1:2009+A1:2011) under system 2 are applied, and that the factory production control fulfils all the prescribed requirements stated therein.
Date of first issue	04.04.2013
Next surveillance audit	03.04.2022
Period of validity	This certificate will remain valid as long as the test methods and/or the factory production control requirements included in the harmonised standard used to assess the performance of the declared character properties do not change, and the product and the manufacturing conditions in the plant are not modified significantly.
Remarks	see reverse

Place and date of issue: Düsselhof 27.02.2019
Düsseldorf

DVS ZERT GmbH, Aachenstraße 172, 40223 Düsseldorf, GERMANY

Achim Janocha
Head of Certification Body

Industrie Service

CERTIFICATE

The certification body for lifts and cranes of TÜV SÜD Industrie Service GmbH Westendstraße 199 80686 München - Deutschland

entitles
Truss Aluminium Factory a.s.
Hodolany 1226
77900 Olomouc - Czech Republic

to identify the product specified below with the test mark shown here.



Product: Welded Aluminium Truss
Type: PT34

This certificate is based on test report, order no. 3211133-15.

This certificate is valid until 2025-04-20.

Certificate registration no. 20.04.9812.012

Filderstadt, 2020-04-21

Achim Janocha
Certification Body „lifts and cranes“



Industrie Service

ZERTIFIKAT ◆ CERTIFICATE ◆ CERTIFICADO ◆ CERTIFICAT ◆ 認證證書 ◆ CERTIFICATE ◆ CERTIFICADO ◆ CERTIFICAT ◆ 認證證書 ◆ CERTIFICATE

CERTIFICATE

The certification body for lifts and cranes of TÜV SÜD Industrie Service GmbH Westendstraße 199 80686 München - Germany

entitles
Truss Aluminium Factory a.s.
Hodolany 1226
77900 Olomouc - Czech Republic

to identify the product specified below with the test mark shown here.



Product: Welded Aluminium Truss
Type: FT34

This certificate is based on test report, order no. 2890560-51.

This certificate is valid until 2021-08-28.

Certificate registration no. 17.08.9812.009

Filderstadt, 2017-08-29

Achim Janocha
Certification Body „lifts and cranes“



Industrie Service

ZERTIFIKAT ◆ CERTIFICATE ◆ CERTIFICADO ◆ CERTIFICAT ◆ 認證證書 ◆ CERTIFICATE ◆ CERTIFICADO ◆ CERTIFICAT ◆ 認證證書 ◆ CERTIFICATE

CERTIFICATE

The certification body for lifts and cranes of TÜV SÜD Industrie Service GmbH Westendstraße 199 80686 München - Deutschland

entitles
Truss Aluminium Factory a.s.
Hodolany 1226
77900 Olomouc - Czech Republic

to identify the product specified below with the test mark shown here.



Product: Welded Aluminium Truss
Type: PT33

This certificate is based on test report, order no. 3211133-15.

This certificate is valid until 2025-05-03.

Certificate registration no. 20.05.9812.013

Filderstadt, 2020-05-04

Achim Janocha
Certification Body „lifts and cranes“



Industrie Service

CERTIFICATE

The certification body for lifts and cranes of TÜV SÜD Industrie Service GmbH Westendstraße 199 80686 München - Deutschland

entitles
Truss Aluminium Factory a.s.
Hodolany 1226
77900 Olomouc - Czech Republic

to identify the product specified below with the test mark shown here.



Product: Welded Aluminium Truss
Type: HT44

This certificate is based on test report, order no. 3211133-14.

This certificate is valid until 2025-06-21.

Certificate registration no. 20.06.9812.016.

Filderstadt, 2020-06-22

Achim Janocha
Certification Body „lifts and cranes“



Industrie Service

TUV®

TUV®

STRUCTURES ALUMINIUM

Page

- 4 **FT23** Structure Aluminium 22 Triangulaire
- 5 **FT23** Structure Aluminium 22 Triangulaire Angles
- 6 **PT33** Structure Aluminium 29 Triangulaire
- 7 **PT33** Structure Aluminium 29 Triangulaire Angles
- 10 **PT34** Structure Aluminium 29 Carrée
- 11 **PT34** Structure Aluminium 29 Carrée Angles
- 12 **FT34** Structure Aluminium 29 Carrée
- 13 **FT34** Structure Aluminium 29 Carrée Angles
- 17 **TOTEM** Aluminium 30 / 40 Carrée
- 18 **HT44** Structure Aluminium 40 Carrée
- 19 **HT44** Structure Aluminium 40 Carrée Cube

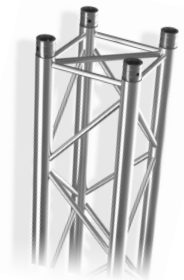
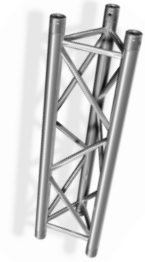

SUPPORT LINE ARRAYS

- 28 **SL236M** Support Line Arrays 30 6 m
- 29 **SL145M** Support Line Arrays 40 5 m
- 31 **SL246M** Support Line Arrays 40 6 m

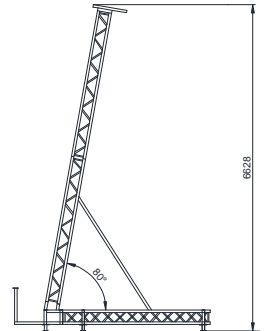

STRUCTURE ACIER

- 36 **A430T** Structure Acier 29 Triangulaire
- 37 **A430C** Structure Acier 29 Carrée

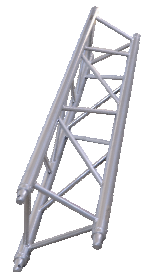

SUPPORT

- 39 **SB188** Support baffle
- 40 **SLCD** Support LCD
- 41 **PSL284** Pied Support Lumière
- 42 **SP310** Pied Support Lumière avec treuil
- 43 **PL370** Pied tour de levage avec treuil
- 43 **PL500** Pied tour de levage avec hexagone
- 45 **PUPITRE**



46 - 47 **SCENE**

46 - 47 **ACCESOIRES**



Présentation de la société

TEM TRUSS fondée en 1997 par **M. Abdelhamid Ghariani**.

TEM TRUSS dispose d'un atelier de fabrication basé à Sfax Capital sud de la Tunisie.

TEM TRUSS est une entreprise spécialisée dans la construction métallique et aluminium, plus particulièrement dans la fabrication des structures métalliques et tout autre produit en corrélation (supports en acier , scènes aluminium , meubles métalliques,...)

Grace au savoir faire de notre équipe et notre expérience dans le domaine de construction métallique.

TEM TRUSS assure la qualité et la fiabilité de fabrication afin de satisfaire les impératifs et les besoins de nos clients.

Notre équipe pouvant intervenir dans tout le territoire tunisien.

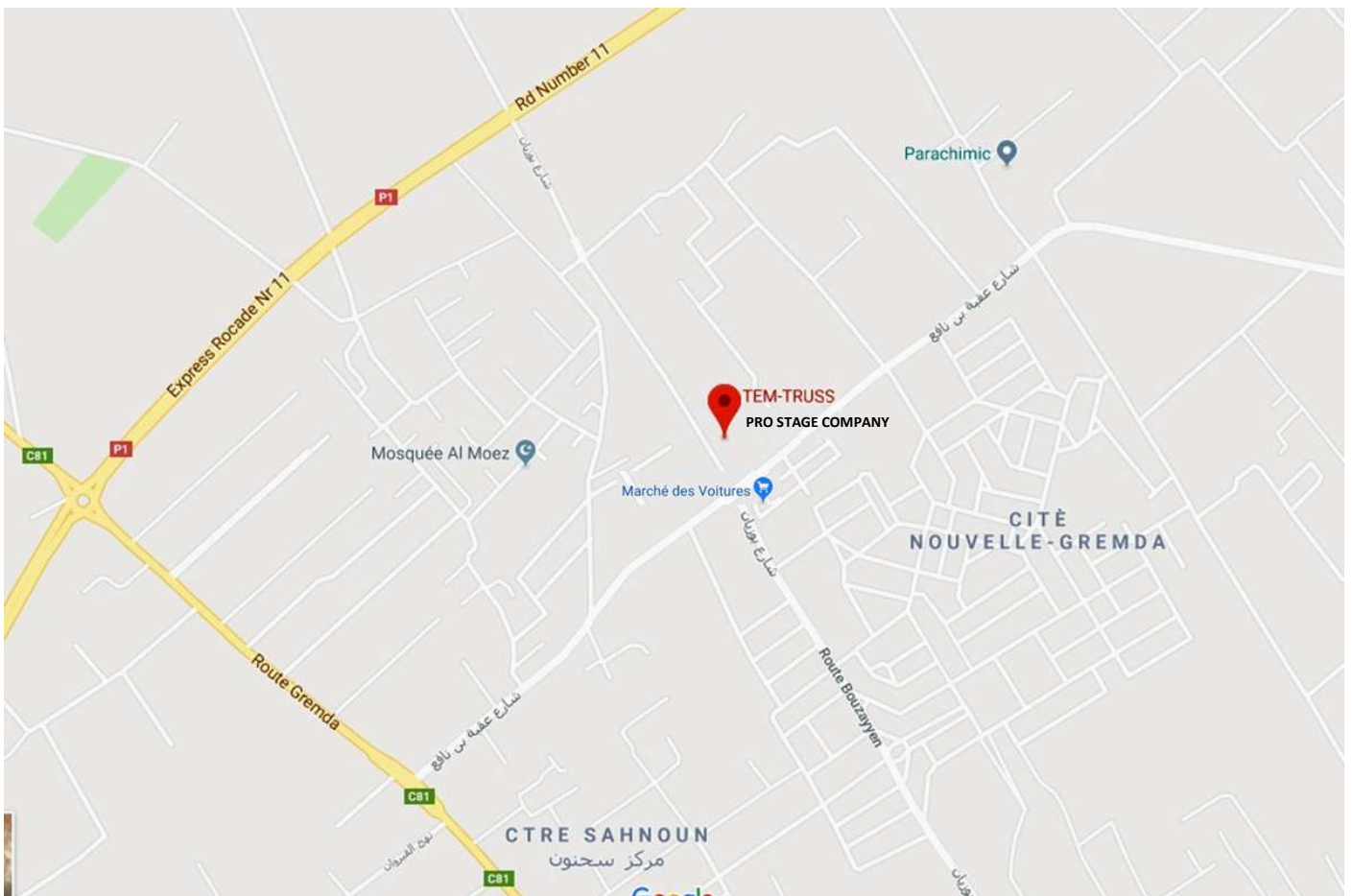



- **Ghariani Tem Truss** Leader dans la fabrication des structures métalliques , est de renommé dans le marché tunisien grâce à la qualité inégalée qu'elle offre ainsi que le développement de ses produits pour répondre aux différents besoins.

- On s'engage à offrir un excellent service à la clientèle



- Nous pouvons vous aider avec toutes les conceptions spécifiques que vous avez désirez.

- Structure en aluminium durable, flexible et polyvalente de tout type de connexion.

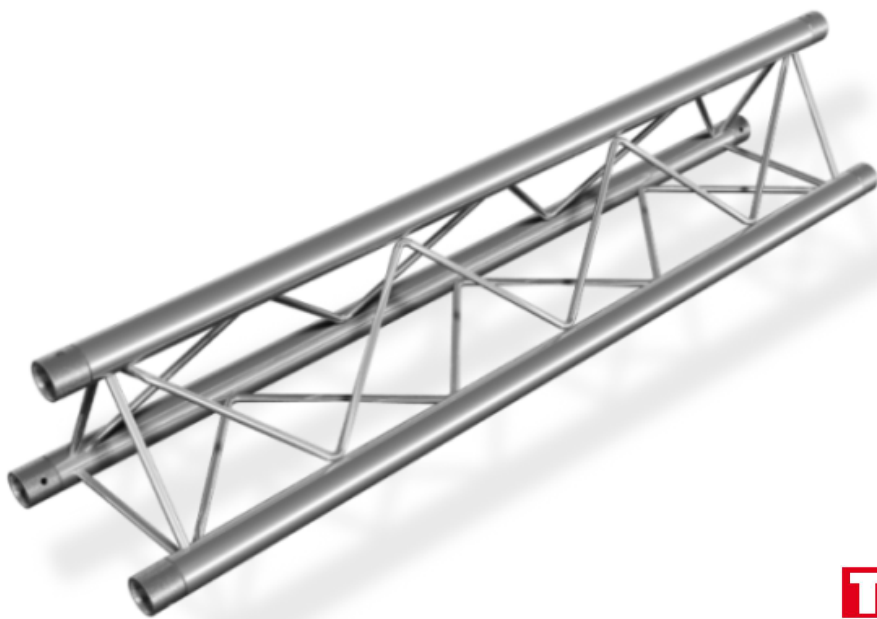

**FT23**

SPECIFICATIONS	
Dimension	220 × 195 mm
Tube porteur	35 × 2 mm
Croisillons	8 mm
Longueur	1 m - 2 m - 3 m
Assemblage	Par manchons coniques

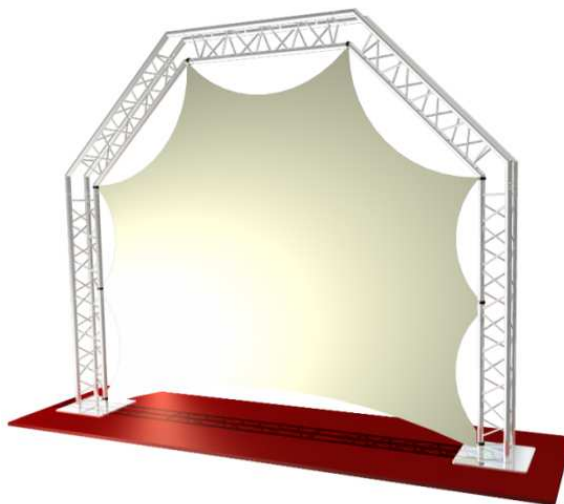
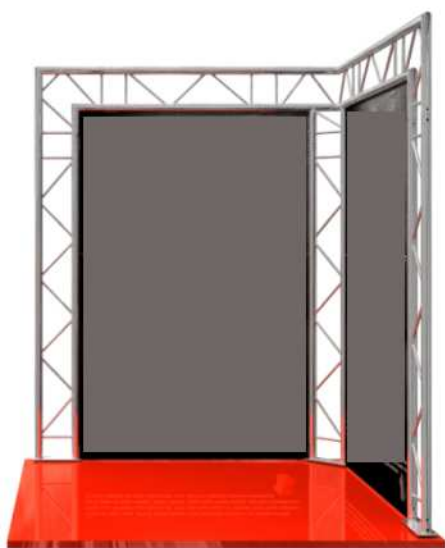



FT23-C25-R

SPECIFICATIONS	
Longueur	500 × 500 mm
Tube porteur	35 × 2 mm
Croisillons	8 mm
Angle	2 directions Arqué
Assemblage	Par manchons coniques



FT23-C25

SPECIFICATIONS	
Longueur	500 × 500 mm
Tube porteur	35 × 2 mm
Croisillons	8 mm
Angle	2 directions
Assemblage	Par manchons coniques

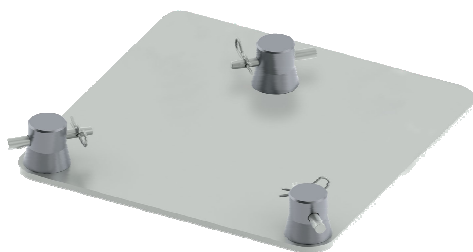

Embase Plate en acier mal FT23

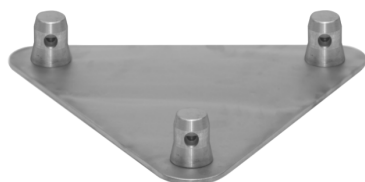

Embase Plate en acier mal FT23



Kit de connections FT23

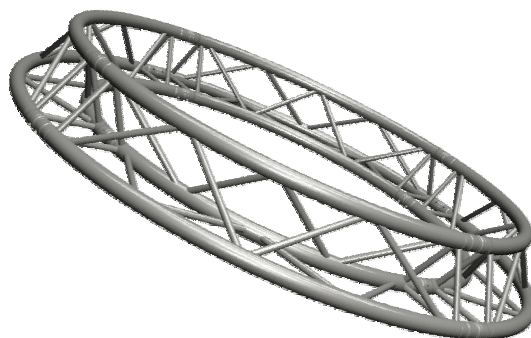

PT33

AL30TC

SPECIFICATIONS	
Dimension	290 × 258 mm
Tube porteur	50 × 2 mm
Croisillons	16 × 2 mm
Assemblage	Par manchons coniques

CERCLE 30 TRIANGULAIRE	
Dimension	290 × 258 mm
Tube porteur	50 × 2 mm
Croisillons	20 × 2 mm
Diamètre	Selon besoin

LONGUEURS STANDARD DISPONIBLES ET POIDS						
Code	PT33-50	PT33-100	PT33-150	PT33-200	PT33-250	PT33-300
Longueurs	0.5 m	1 m	1.5 m	2 m	2.5 m	3 m
Poids	2.5 kg	4.1 kg	5.8 kg	7.4 kg	9.1 kg	10.7 kg

TABLEAU DE CHARGE						
Longueurs	2 m	4 m	6 m	8 m	10 m	12 m
Distrib (kg/m)	680	206	97	54	33	20
Déflexion (mm)	2.3	11.5	28.1	51	78.3	107.2

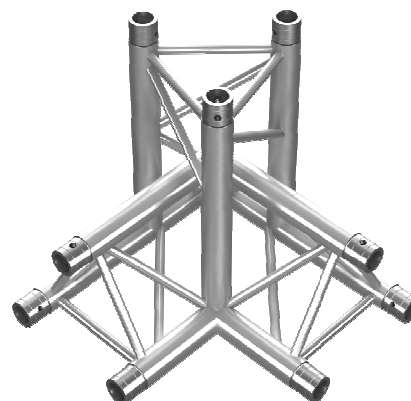
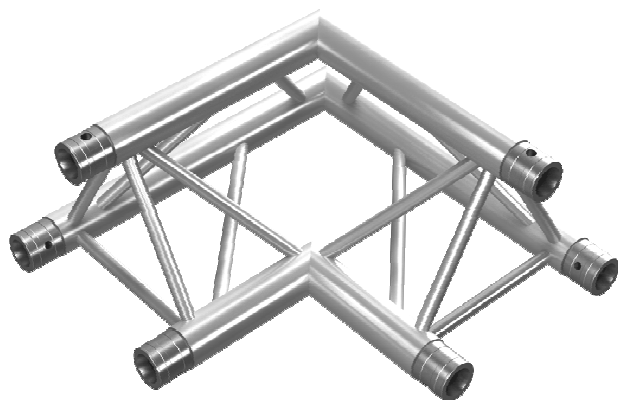

PT33-C21

SPECIFICATIONS	
Longueur	500 × 500 mm
Tube porteur	50 × 2 mm
Croisillons	16 × 2mm
Angle	2 directions
Assemblage	Par manchons coniques

PT33-C30

SPECIFICATIONS	
Longueur	500 × 500 x 500 mm
Tube porteur	50 × 2 mm
Croisillons	16 × 2mm
Angle	3 directions
Assemblage	Par manchons coniques

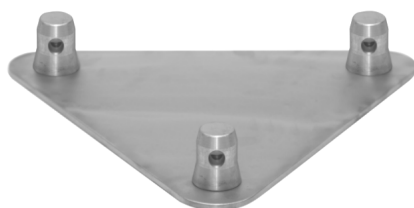

Embase Plate en ALU mal PT33



Kit de connections PT33



#5102

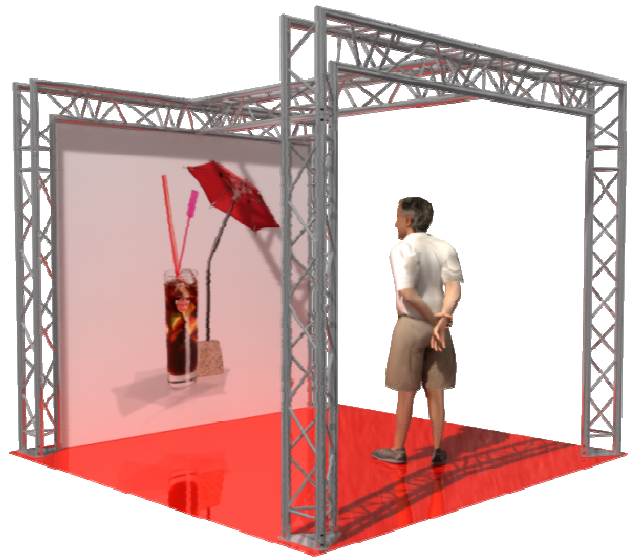

#5103

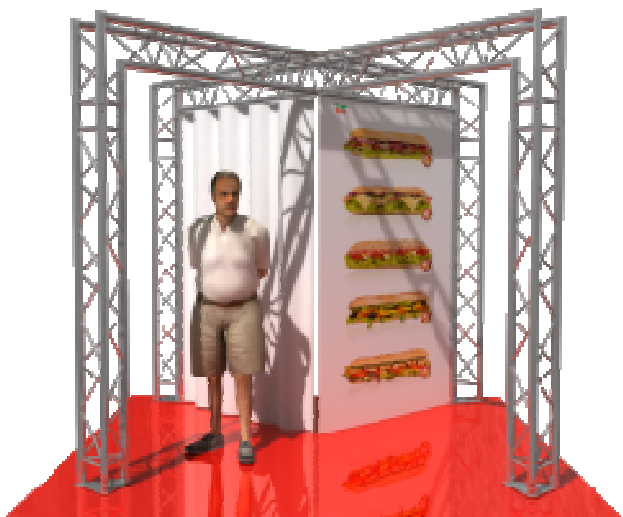

#5104

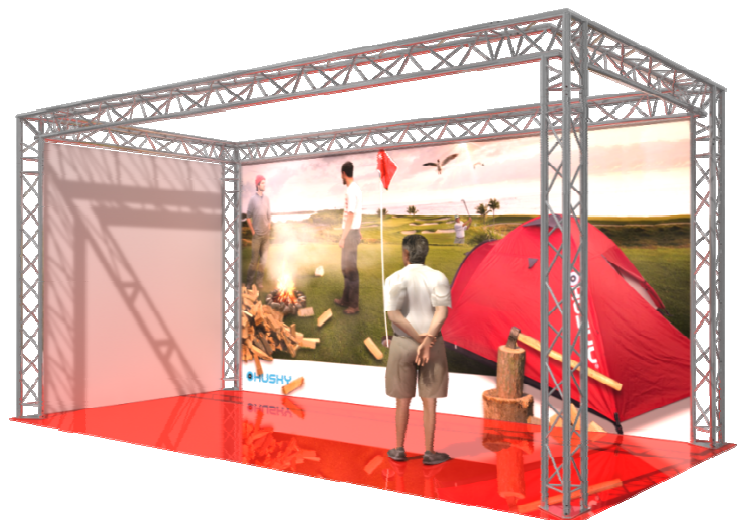

#5201

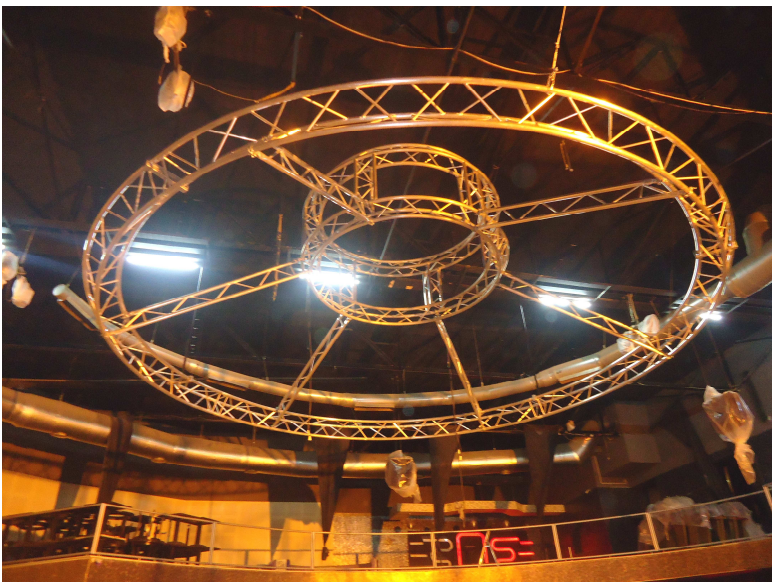

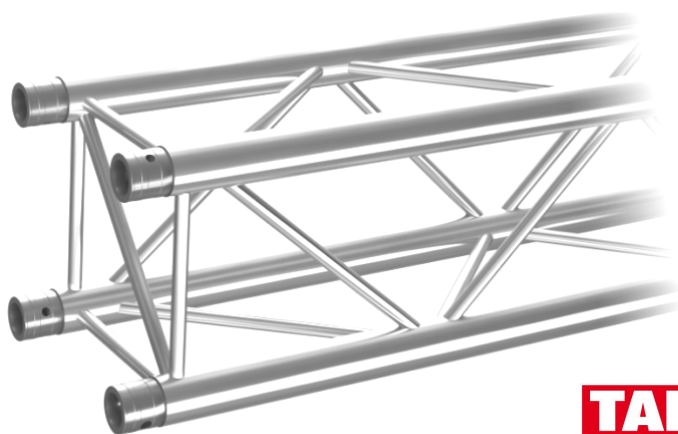

PT34

AL30CC

SPECIFICATIONS	
Dimension	290 × 290 mm
Tube porteur	50 × 2 mm
Croisillons	16 × 2 mm
Assemblage	Par manchons coniques

CERCLE 30 CARRÉ	
Dimension	290 × 290 mm
Tube porteur	50 × 2 mm
Croisillons	20 × 2 mm
Diamètre	Selon besoin

LONGUEURS STANDARD DISPONIBLES ET POIDS						
Code	PT34-50	PT34-100	PT34-150	PT34-200	PT34-250	PT34-300
Longueur	0.5 m	1 m	1.5 m	2 m	2.5 m	3 m
Poids	3.4 kg	5.7 kg	7.9 kg	10.1 kg	12.5 kg	14.5 kg

TABLEAU DE CHARGE						
Longueur	2 m	4 m	6m	8 m	10 m	12 m
Distrib (kg/m)	785	390	229	130	81	53
Déflexion (mm)	1.4	10.8	32.5	59.3	92.5	130.3

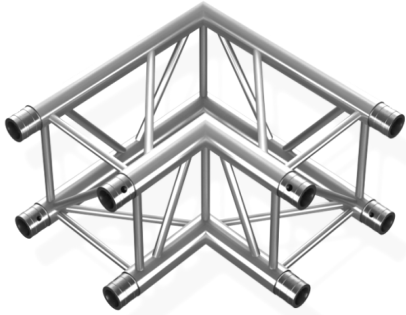

PT34-C21

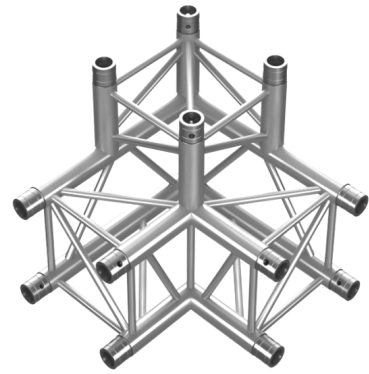

PT34-C30

SPECIFICATIONS	
Longueur	500 × 500 mm
Tube porteur	50 × 2 mm
Croisillons	16 × 2 mm
Angle	2 directions
Assemblages	Par manchons coniques

SPECIFICATIONS	
Longueur	500 × 500 x 500 mm
Tube porteur	50 × 2 mm
Croisillons	16 × 2 mm
Angle	3 directions
Assemblages	Par manchons coniques

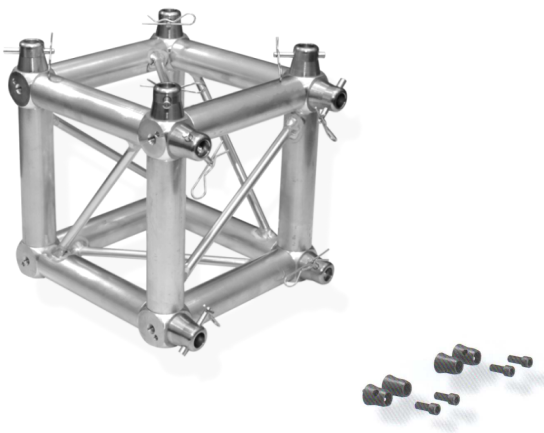

PT34-MCB

CUBE de jonction PT34



3004

Embase Plate en ALU mal PT34



Kit de connexion PT34



Manchon charnière PT34

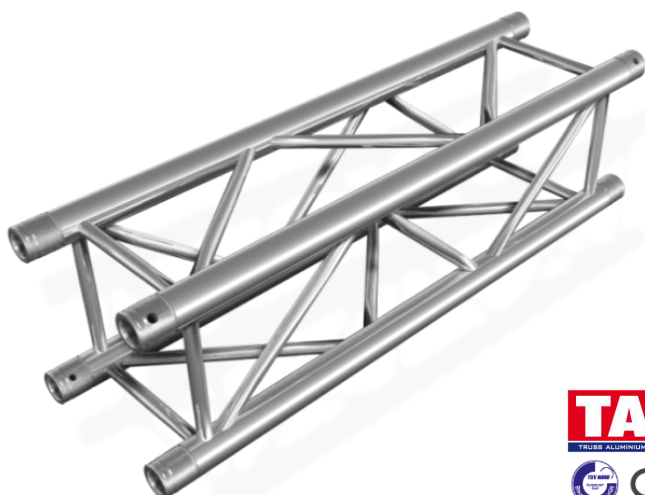

FT34

AL30CC

SPECIFICATIONS	
Dimension	290 × 290 mm
Tube porteur	50 × 2 mm
Croisillons	20 × 2 mm
Assemblage	Par manchons coniques

CERCLE 30 CARRÉ	
Dimension	290 × 290 mm
Tube porteur	50 × 2 mm
Croisillons	20 × 2 mm
Diamètre	Selon besoin

LONGUEURS STANDARD DISPONIBLES ET POIDS							
Code	FT34-50	FT34-100	FT34-150	FT34-200	FT34-250	FT34-300	FT34-400
Longueur	0.5 m	1 m	1.5 m	2 m	2.5 m	3 m	4 m
Poids	3.8 kg	6.1 kg	8.5 kg	10.8 kg	13.2 kg	15.6 kg	20.3 kg

TABLEAU DE CHARGE						
Longueur	2 m	4 m	6m	8 m	10 m	12 m
Distrib (kg/m)	1422	493	223	127	79	51
Déflexion (mm)	2.4	13.7	31.8	58	90.5	126.4

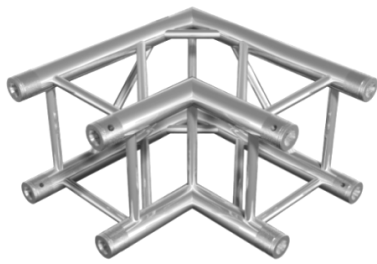

FT34-C21

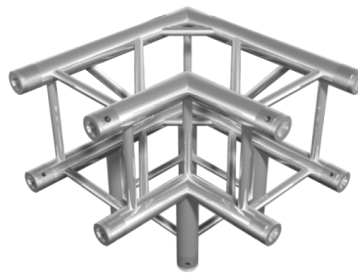

FT34-C30

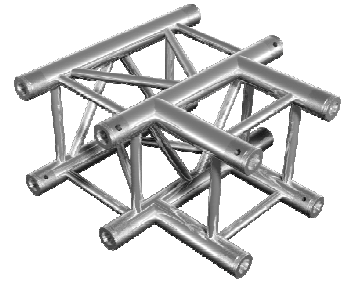

FT34-T35

SPECIFICATIONS	
Longueur	500 × 500 mm
Tube porteur	50 × 2 mm
Croisillons	20 × 2mm
Angle	2 directions
Assemblages	Par manchons coniques

SPECIFICATIONS	
Longueur	500 × 500 x 500 mm
Tube porteur	50 × 2 mm
Croisillons	20 × 2mm
Angle	3 directions / Forme T
Assemblages	Par manchons coniques

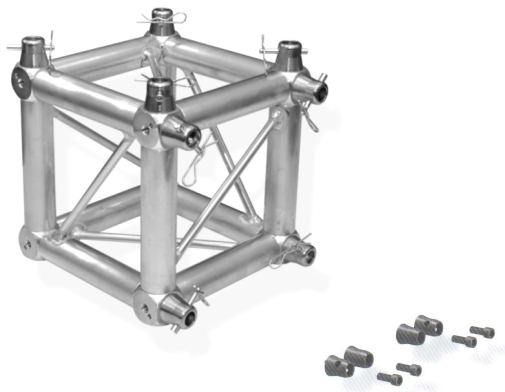

FT34-MCB

CUBE de jonction FT34

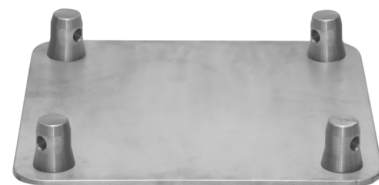

3004

Embase Plate en ALU mal FT34



Kit de connections FT34



Manchon charnière FT34



#5101



#5202



#5204



#5301

TOUR DE LEVAGE STRUCTURE MODÈLE ALUMINIUM

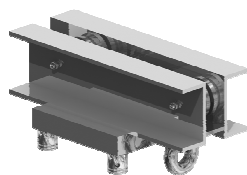

TT TS

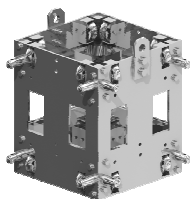

TT SB



TT LO

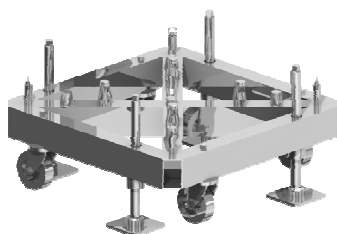

TT BP



COMMANDE POUR MOTEURS



MOTEUR À CHAÎNE

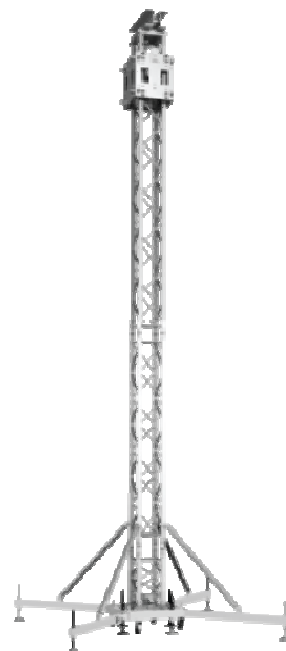

TOUR DE LEVAGE STRUCTURE MODÈLE ACIER



TETE DE TOUR

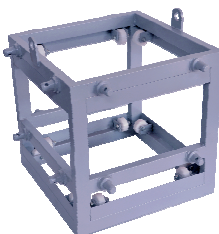

CHARIOT



EMBASE



FLIGHT CAISE POUR MOTEURS



PALAN À CHAÎNE



TOTEM



TOTEM 34

SPECIFICATIONS

Structure 30 Carré	PT34 / FT34
Hauteur	1 m - 1.5 m - 2 m - 2.5 m - 3 m
Plate forme ALU	0.35 × 0.35 m / 0.50 × 0.50 m
Diamètre embase	0.75 m - 1 m



TOTEM 44

SPECIFICATIONS

Structure 40 Carré	HT44
Hauteur	1 m - 2 m - 3 m
Plate forme ALU	0.50 × 0.50 m
Diamètre embase	0.75 m - 1 m

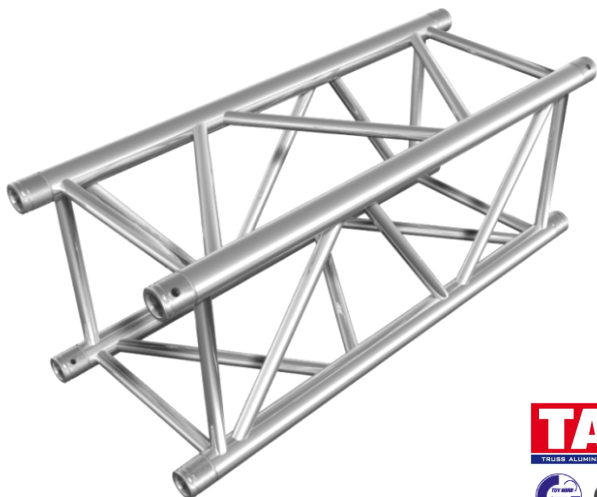

HT44

AL40CC

SPECIFICATIONS	
Dimension	400 x 400 mm
Tube porteur	50 x 3 mm
Croisillons	25 x 3 mm
Assemblage	Par manchons coniques

CERCLE 39 CARRÉ	
Dimension	390 x 390 mm
Tube porteur	50 x 2 mm
Croisillons	19 x 2 mm
Diamètre	Selon besoin

LONGUEURS STANDARD DISPONIBLES ET POIDS							
Code	HT44-50	HT44-100	HT44-150	HT44-200	HT44-250	HT44-300	HT44-400
Longueur	0.5 m	1 m	1.5 m	2 m	2.5 m	3 m	4 m
Poids	5.6 kg	9.7 kg	13.4 kg	16.9 kg	20.6 kg	24.6 kg	31.9 kg

TABLEAU DE CHARGE						
Longueur	2 m	4 m	6 m	8 m	10 m	12 m
Distrib (kg/m)	2327	901	417	243	162	112
Déflexion (mm)	1.3	8	18.9	35.4	58.8	86.5

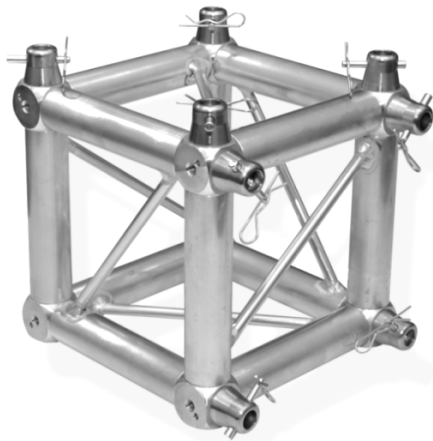

HT44-MCB

CUBE de jonction HT44



4004

Embase Plate en ALU mal HT44



BL40C

Embase lourde en acier mal HT44 \varnothing 1 m



Kit de connections HT44



Manchon charnière HT44

STRUCTURES ALUMINIUM





STRUCTURES ALUMINIUM

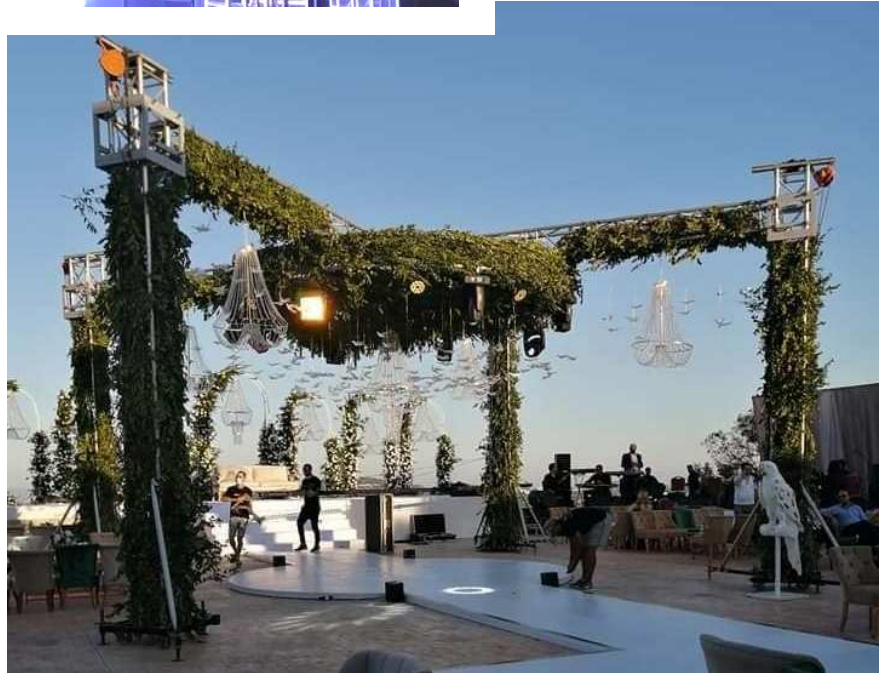

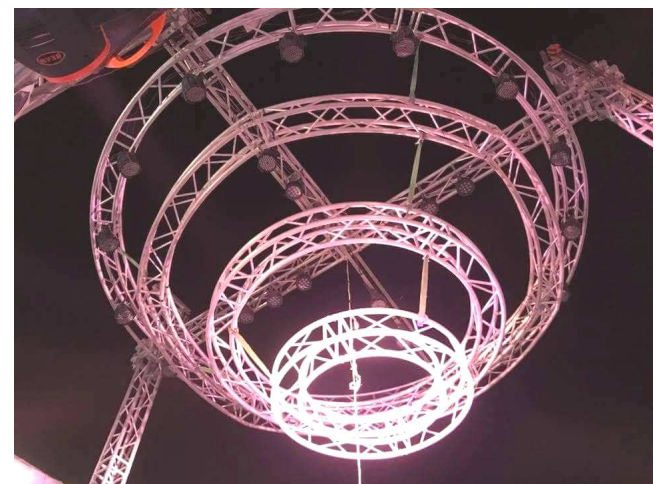
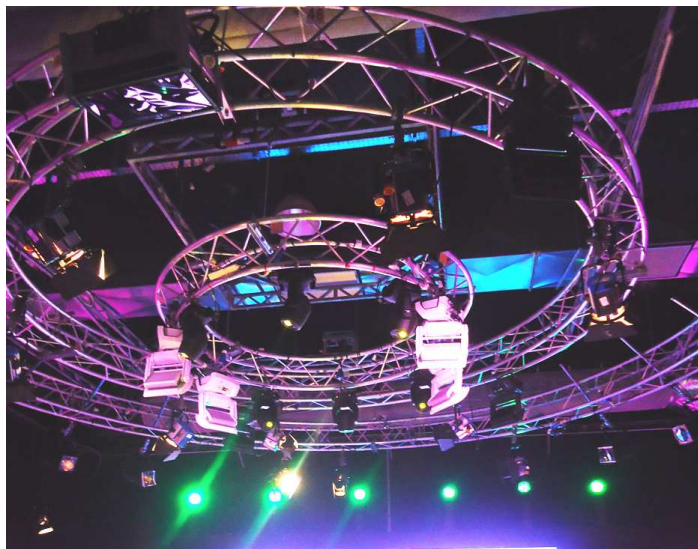

STRUCTURES ALUMINIUM

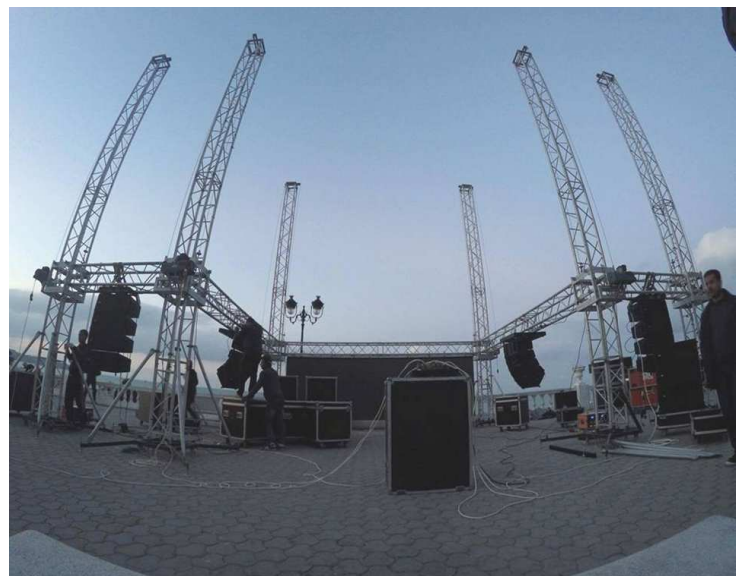
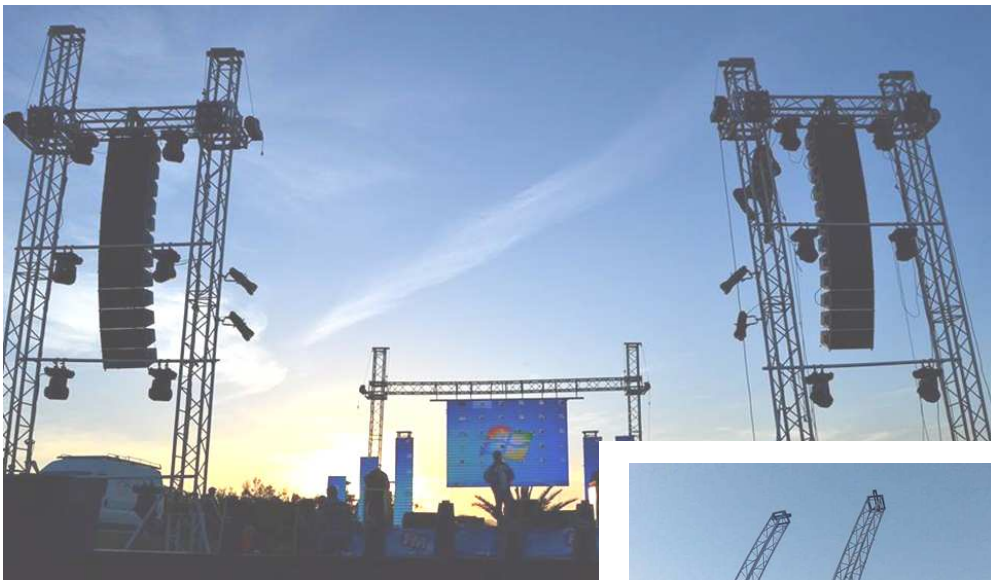



STRUCTURE DE TOITURE ALUMINIUM

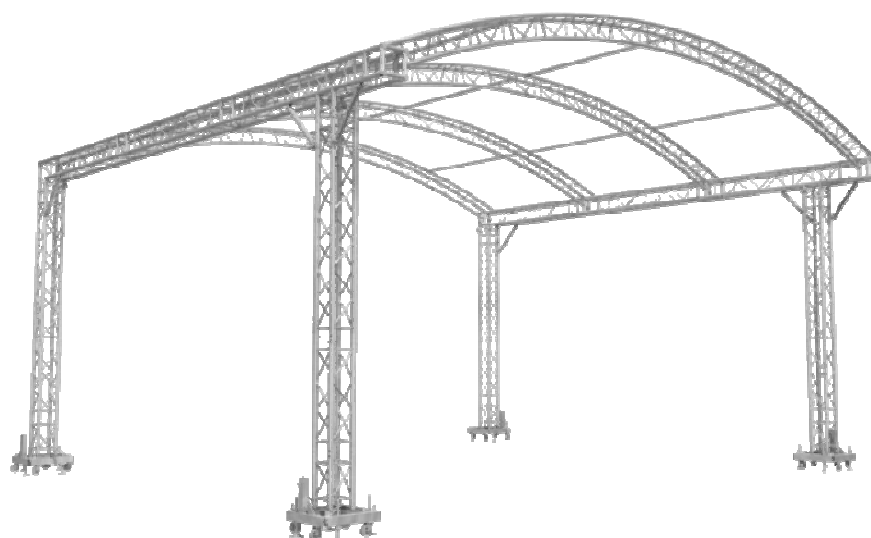
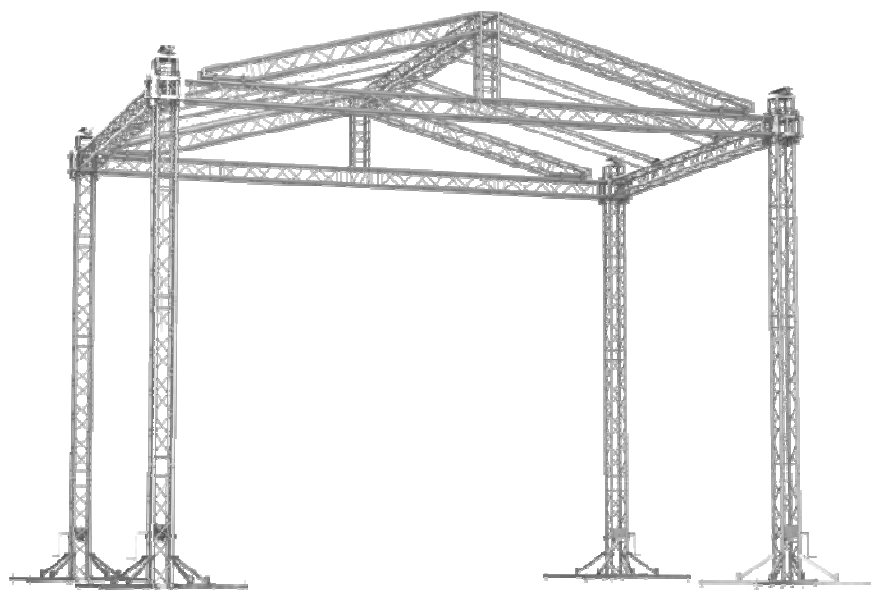
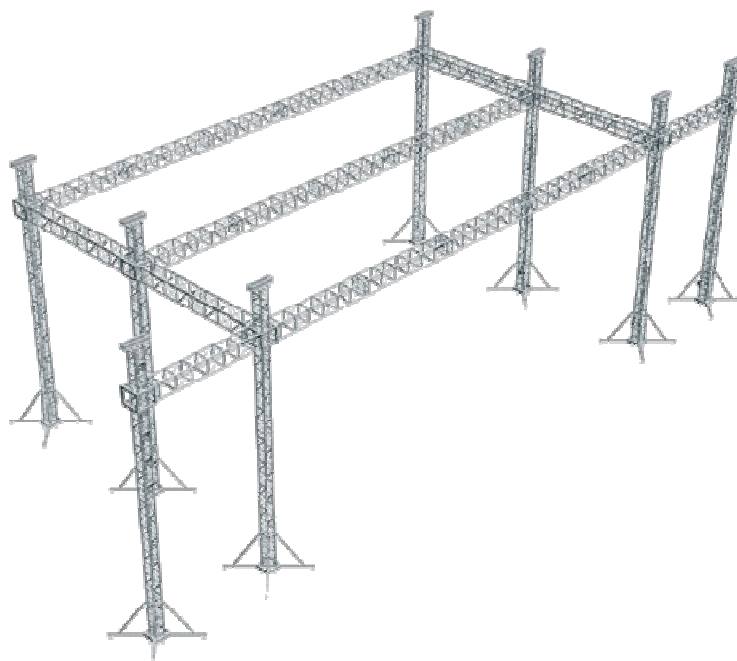



SUPPORT LINE ARRAYS



Tour d'accroche pour système audio, réalisées avec des structures FT34, supportant des charges de 600 kg 6,5 m de hauteur.

SL236M

Structure	FT34
Hauteur	6.50 m
Charge	600 kg

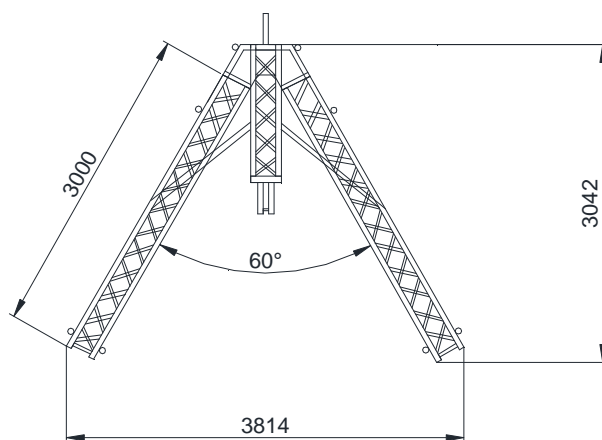
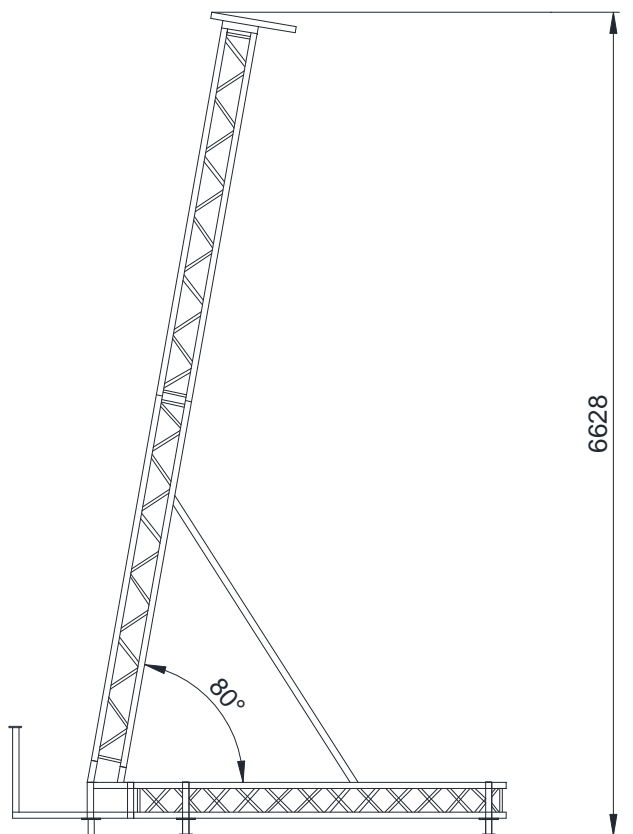

SUPPORT LINE ARRAYS



Tour d'accroche pour système audio, réalisées avec des structures HT44, supportant des charges de 800 kg de hauteur 5,5m.

SL145M

Structure	HT44
Hauteur	5.50 m
Charge	800 kg

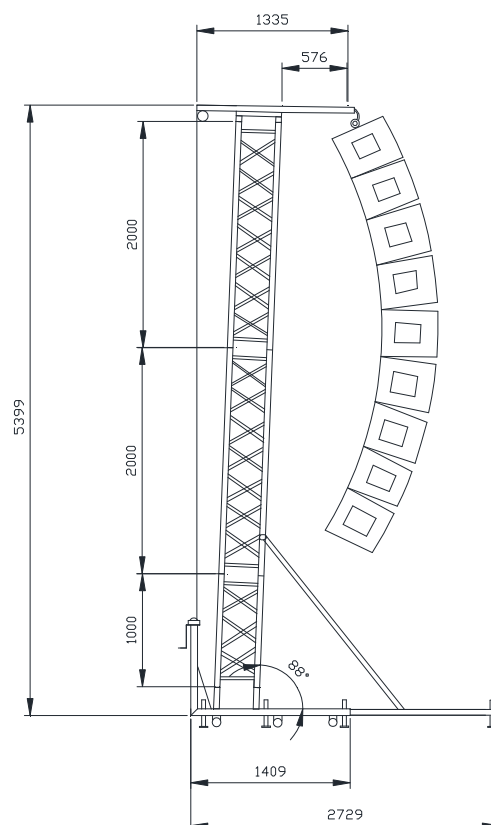

SUPPORT LINE ARRAYS



SUPPORT LINE ARRAYS

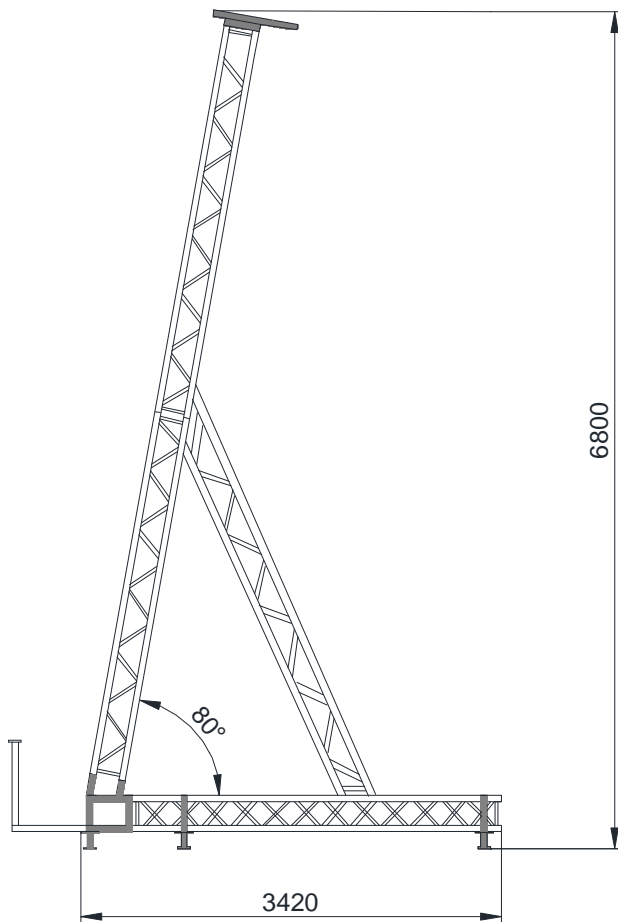

Tour d'accroche pour système audio, réalisées avec des structures HT44, supportant des charges de 800 kg de hauteur 6.5 m.

SL246M

Hauteur	6.5 m
Charge	800 kg
Dimension	400 × 400 mm
Tube porteur	50 × 3 mm
Croisillons	25 × 3 mm

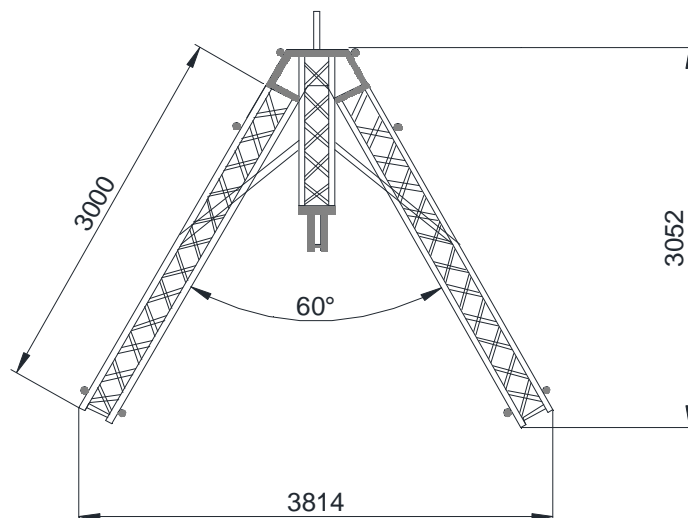

STRUCTURES ACIER

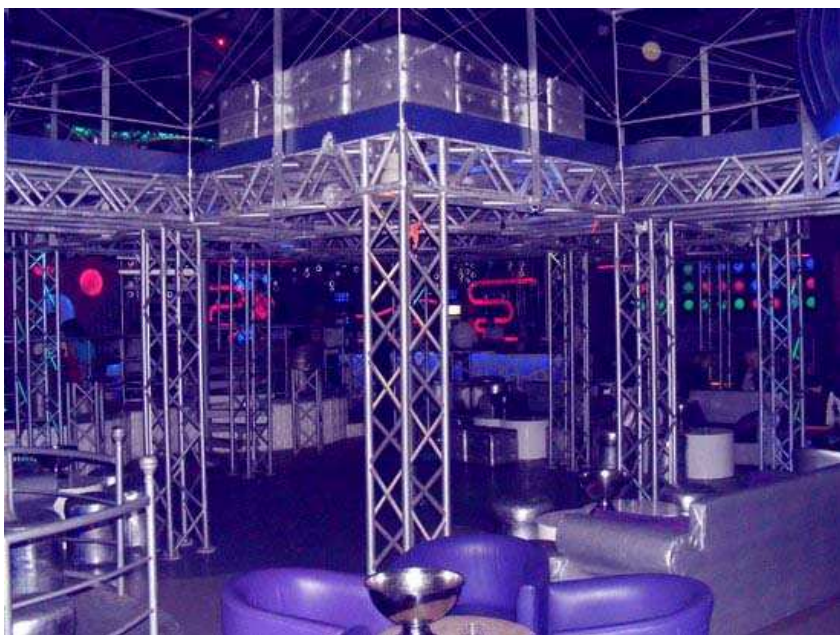
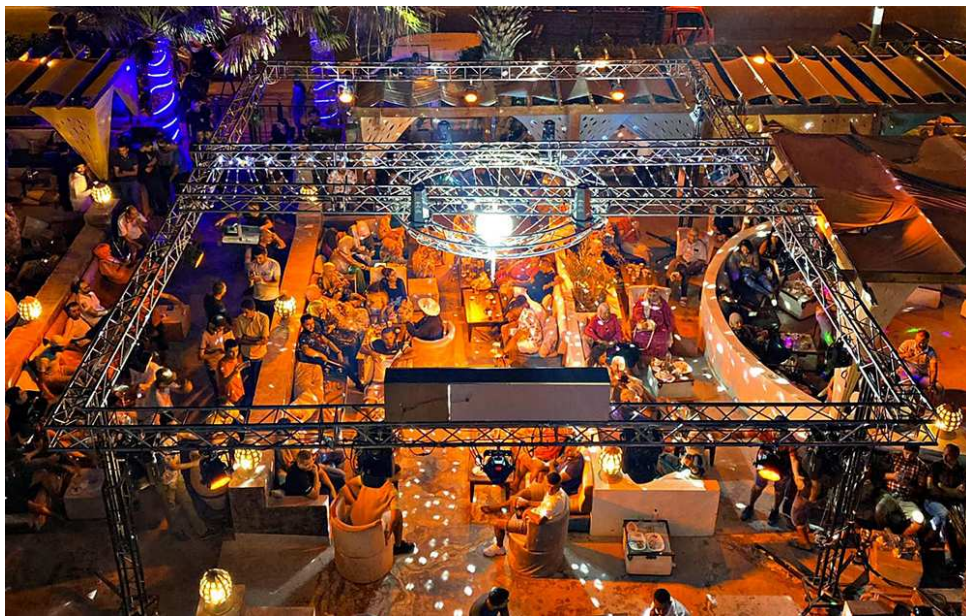
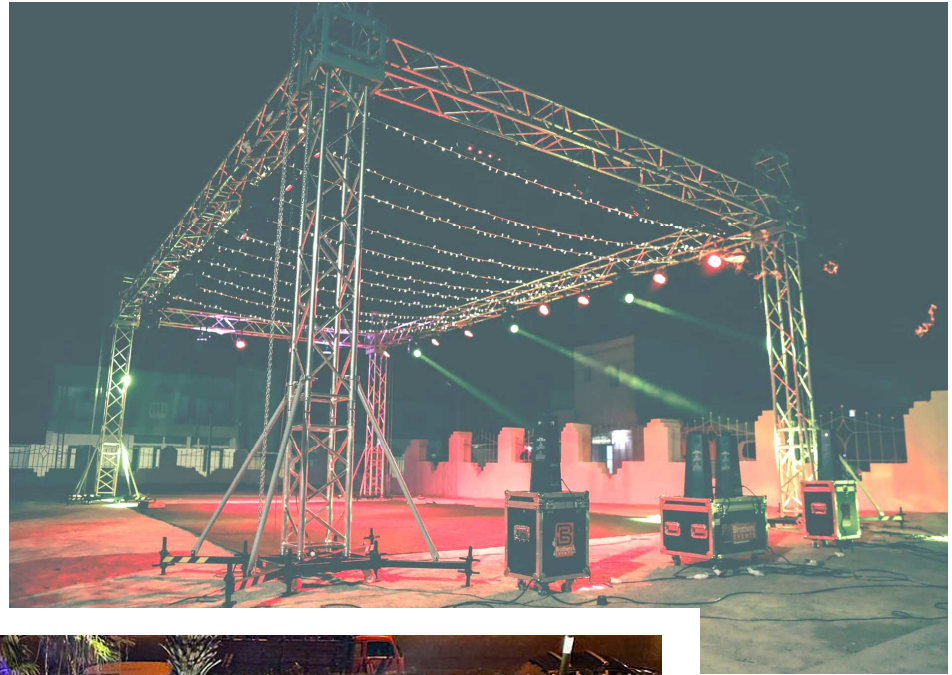

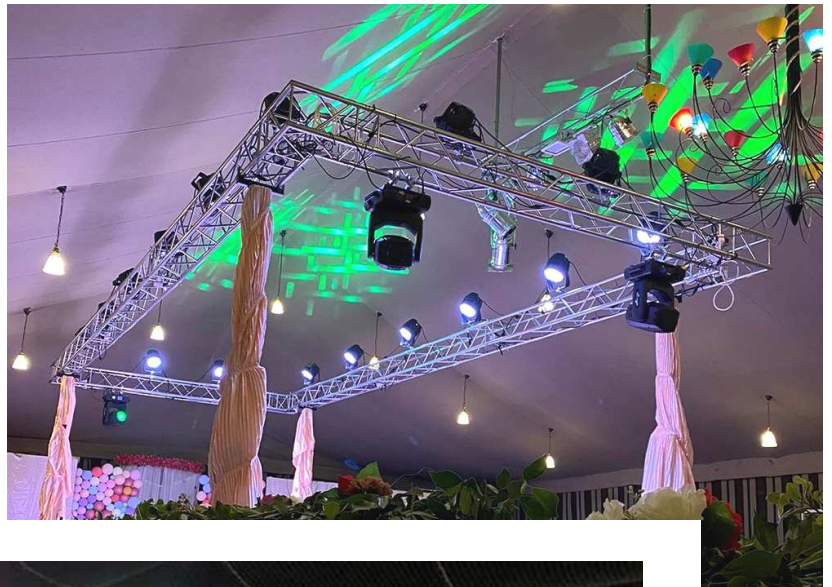

STRUCTURES ACIER



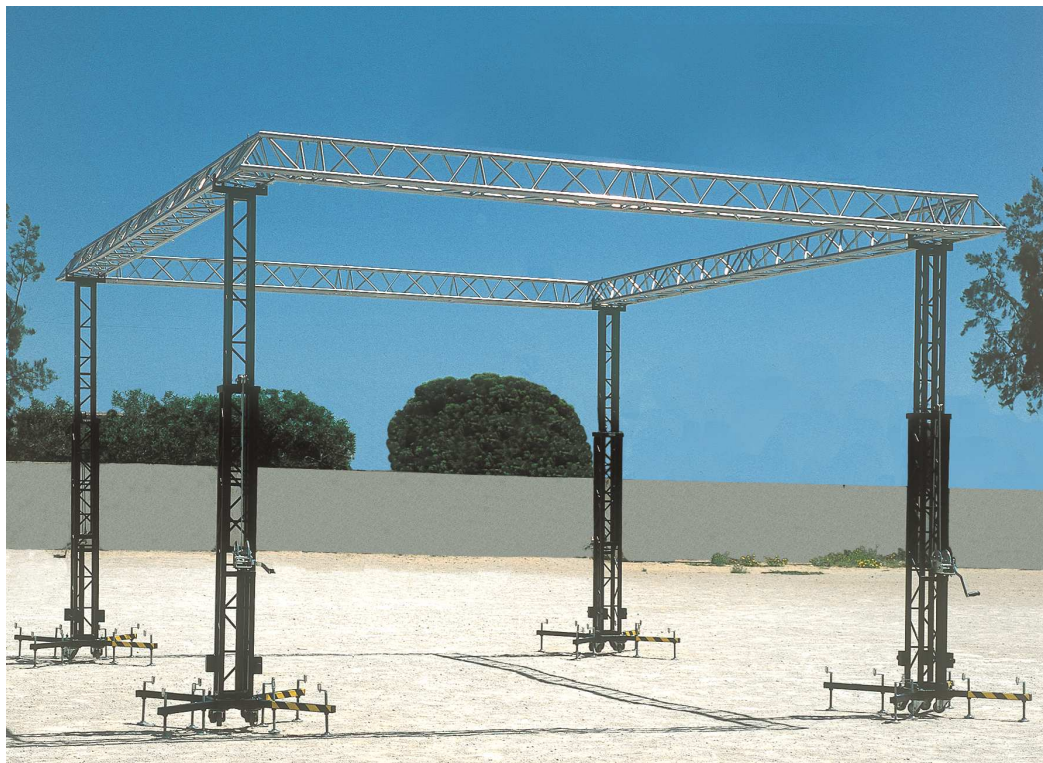
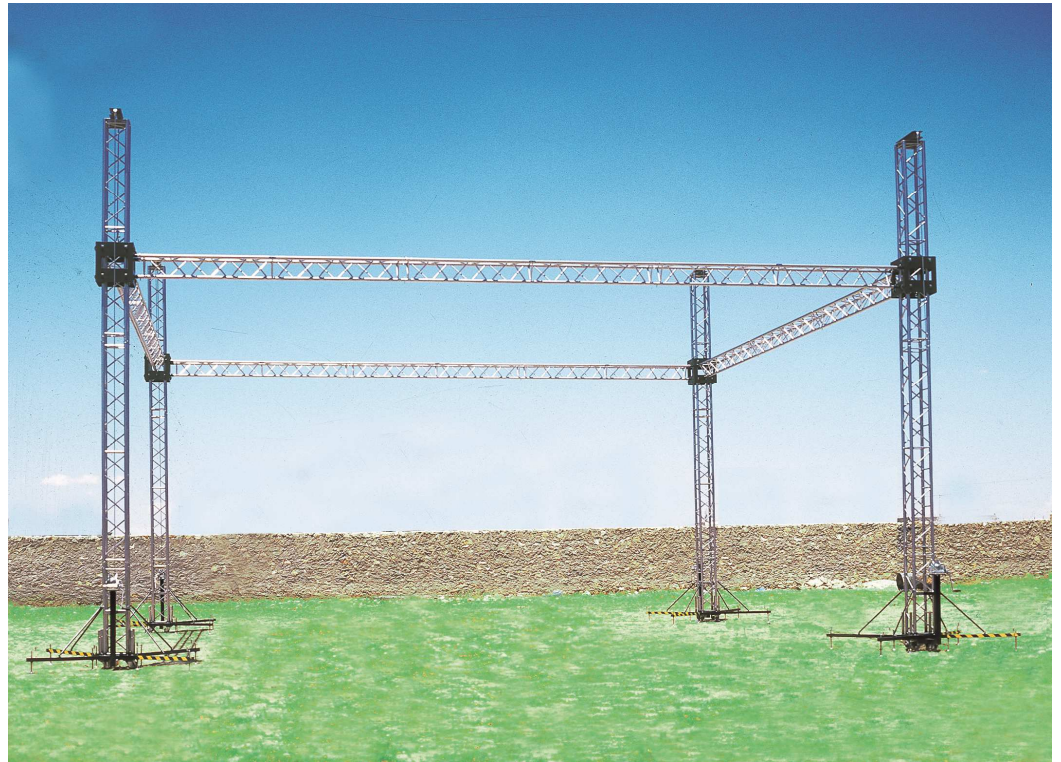

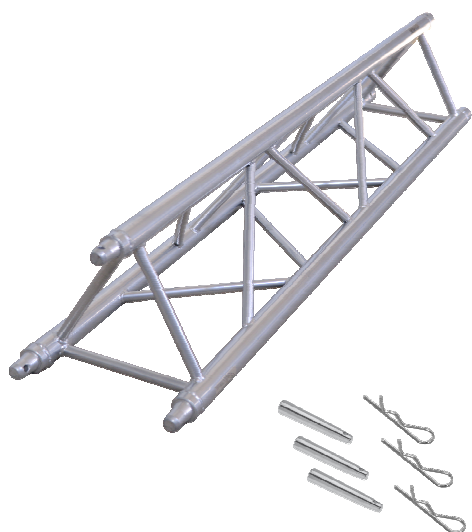

STRUCTURE TRIANGULAIRE 30 T

SPECIFICATIONS	
Dimension	290 × 247 mm
Longueur	0.5 m - 6 m
Finition	Noir époxy /Gris

Kit de connection

LONGUEURS STANDARD DISPONIBLES ET POIDS							
Code	A4305T	A431T	A4315T	A432T	A4325T	A433T	A434T
Longueur	0.5 m	1 m	1.5 m	2 m	2.5 m	3 m	4 m
Poids	4.4 kg	8.3 kg	9.7 kg	11.3 kg	13.9 kg	15.8 kg	22 kg

AT 432 D

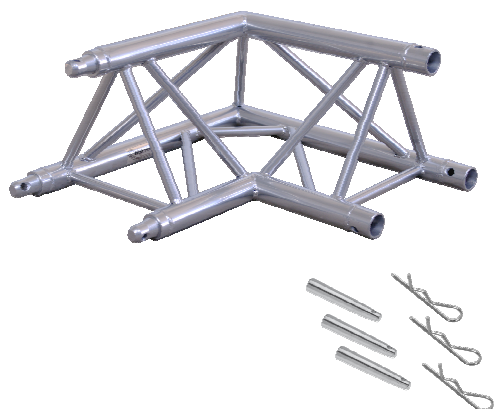

SPECIFICATIONS	
Dimension	500 × 500 mm
Angle	Selon besoin (2 -3- 4 directions)
Finition	Noir époxy /Gris

Kit de connection

CIRCULAIRE 30 T

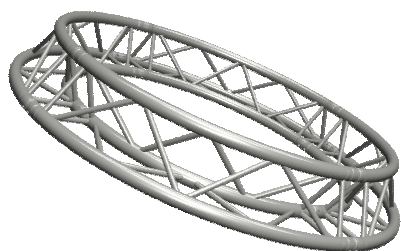

SPECIFICATIONS	
Dimension	290 × 247 mm
Diamètre	Selon besoin
Finition	Noir époxy / Gris

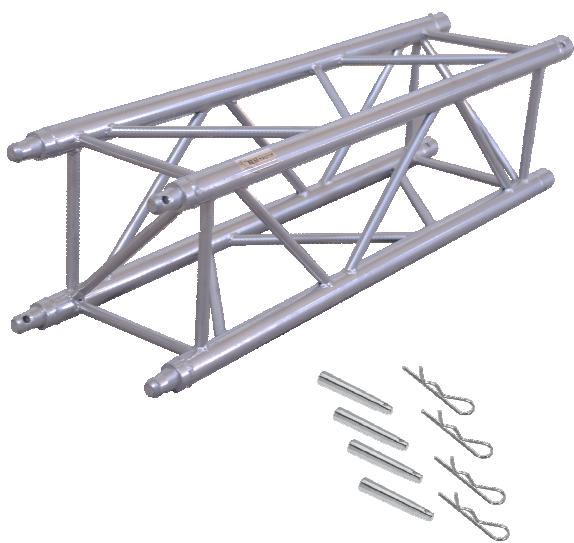

STRUCTURE CARRE 30 C

SPECIFICATIONS	
Dimension	290 × 290 mm
Longueur	0.5 m - 6 m
Finition	Noir époxy /Gris

Kit de connection

LONGUEURS STANDARD DISPONIBLES ET POIDS							
Code	A4305C	A431C	A4315C	A432C	A4325C	A433C	A434C
Longueur	0.5 m	1 m	1.5 m	2 m	2.5 m	3 m	4 m
Poids	5 kg	9.2 kg	11.5 kg	15.2 kg	19.8 kg	22.2 kg	30.2 kg

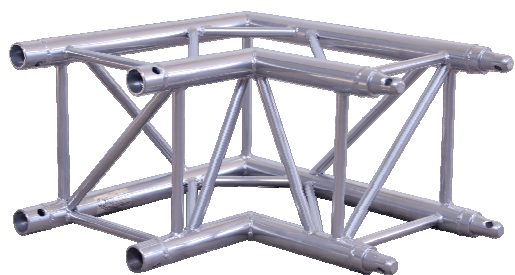

AC 432 D

SPECIFICATIONS	
Dimension	500 × 500 mm
Angle	Selon besoin (2 -3- 4 directions)
Finition	Noir époxy /Gris

Kit de connection

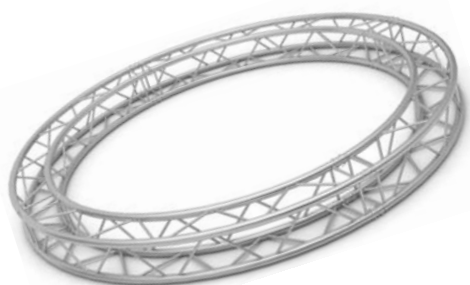

CIRCULAIRE 30 C

SPECIFICATIONS	
Dimension	290 × 290 mm
Diamètre	Selon besoin
Finition	Noir époxy / Gris

SUPPORTS

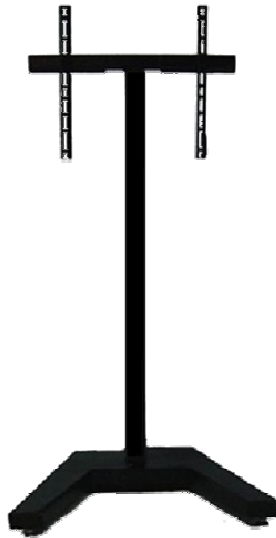

**SB 188 C**

SPECIFICATIONS	
Hauteur Min	1.27 m
Hauteur Max	1.88 m
Poids / Charge	4.300 kg / 40 kg
Diamètre de la base	0.85 m
Finition	Chromé

**SB 188 N**

SPECIFICATIONS	
Hauteur Min	1.27 m
Hauteur Max	1.88 m
Poids / Charge	4.300 kg / 40 kg
Diamètre de la base	0.85 m
Finition	Noir époxy

SUPPORTS

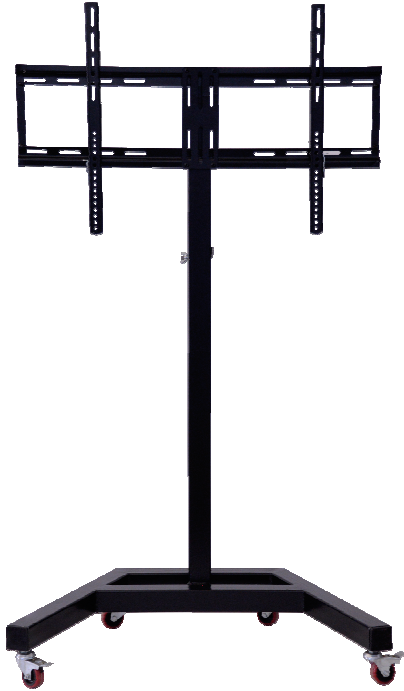

SLCD

SPECIFICATIONS

Hauteur Min	1.23 m
Hauteur Max	1.82 m
Pour Ecran LCD	30" - 63"
Finition	Noir époxy



SM LCD

SPECIFICATIONS

Hauteur	0.75 m
Angle Réglable	45" - 90"
Pour Ecran LCD	30" - 63"
Finition	Noir époxy

**P S L 284**

SPECIFICATIONS	
Hauteur Min	1.83 m
Hauteur Max	2.84 m
Poids	6.600 kg
Finition	Noir époxy

**S P 150 N**

SPECIFICATIONS	
Hauteur Min	1.83 m
Hauteur Max	2.87 m
Poids	7.800 kg
Finition	Noir époxy

SUPPORTS



SP 310

SPECIFICATIONS	
Hauteur Min	1.95 m
Hauteur Max	3.10 m
Poids / Charge	15.500 kg / 70 kg
Diamètre de la base	1.80 m
Finition	Noir époxy



SPT 200

SPECIFICATIONS	
Hauteur Min	1.95 m
Hauteur Max	3.10 m
Structure	29 T Longueur 2 m
Diamètre de la base	1.80 m
Finition	Noir époxy / Gris

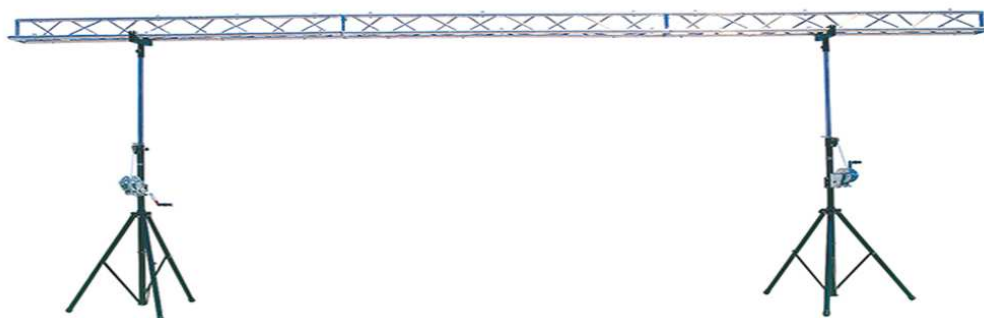

SL 600T

SPECIFICATIONS	
Hauteur Min / Max	1.95 m / 3.10 m
Structure	29 T Longueur 6 m
Charge	150 kg
Diamètre de la base	1.80 m
Finition	Noir époxy / Gris



PL 350

SPECIFICATIONS	
Hauteur Min	1.80 m
Hauteur Max	3.50 m
Charge	150 kg
Diamètre de la base	1.55 m
Finition	Noir époxy / Gris

PL 400

SPECIFICATIONS	
Hauteur Min	2.10 m
Hauteur Max	4 m
Charge	250 kg
Diamètre de la base	1.75 m
Finition	Noir époxy / Gris



PL 500

SPECIFICATIONS	
Hauteur Min	2.78 m
Hauteur Max	5 m
Diamètre de l'Hexagone	1 m
Diamètre de la base	2.46 m
Finition	Noir époxy / Gris

SUPPORT



SMP

Support TV Mural de plafond réglable



SEM01

Support d'enceinte Mural



SMIC

Support MICRO de studio

PUPITRE



SCENE ACIER

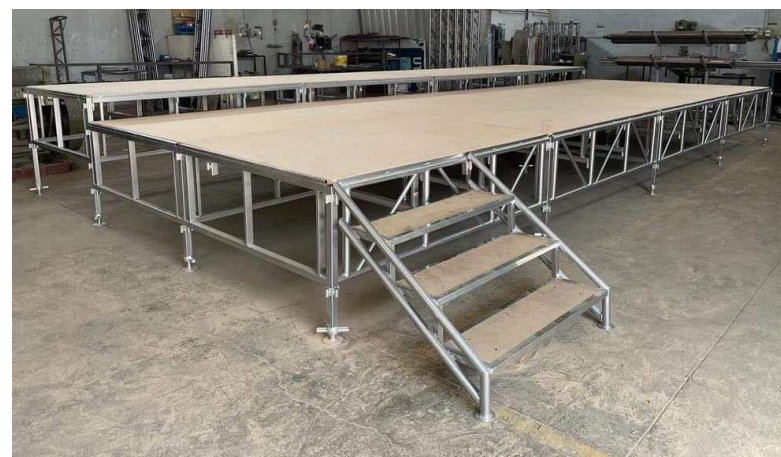
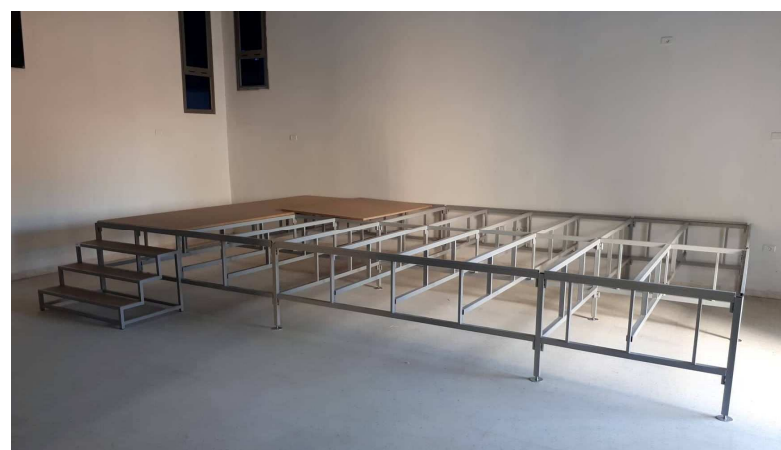

SCENE ALUMINIUM



ACCESSOIRES



8001

Collier ALU pour tube
48-51 mm Charge 500 kg
avec boulon M10



8002

Collier ALU pour tube
48-51 mm Charge 250 kg
avec boulon M10



8003

Double collier ALU pour tube
48-51 mm Charge 500 kg



8004

Crochet ALU pour tube
48-51 mm Charge 250 kg



8011

Collier ALU pour tube
48-51 mm Charge 100 kg



8016

Crochet ALU pour tube
48-51 mm charge 250 kg



8031

Collier ALU pour tube
48-51 mm avec demi manchon



8033

Double collier ALU pour tube
48-51 mm Charge 250 kg



8104

Accrochage câble



CP30Z

Crochet pour Projecteur



3146

Kit de connections



3190

Manchon charnière



6010-60-4

Câble de sécurité



VN45

Vérin mise à niveau



Protection câble

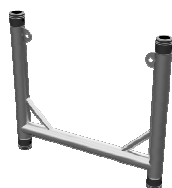

5555

Support forme U pour projecteur

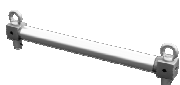

5556

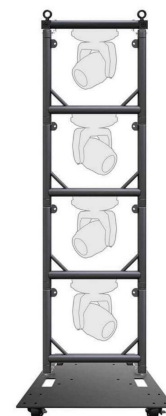



BL30T

Base plate Triangulaire
FT 23 / FT 33



3004

Base plate en ALU FT34 / PT34
33 x 33 cm



4004

Base plate en ALU HT44
50 x 50 cm



PAL40

Base plate en acier 40 x 40 cm



BL30C

Base lourde \varnothing 75 x 0.6 cm
Poids 23.200 kg



BL40C

Base lourde \varnothing 100 x 1 cm
Poids 65 kg

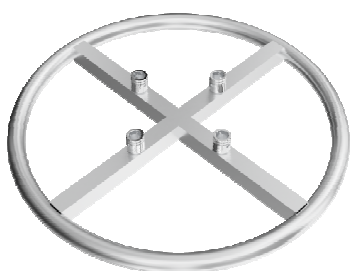

8203

Totem ALU cercle \varnothing 1 m



BFL

Barre ALU forme L avec 2 colliers



CEL

Chariot pour embases lourdes



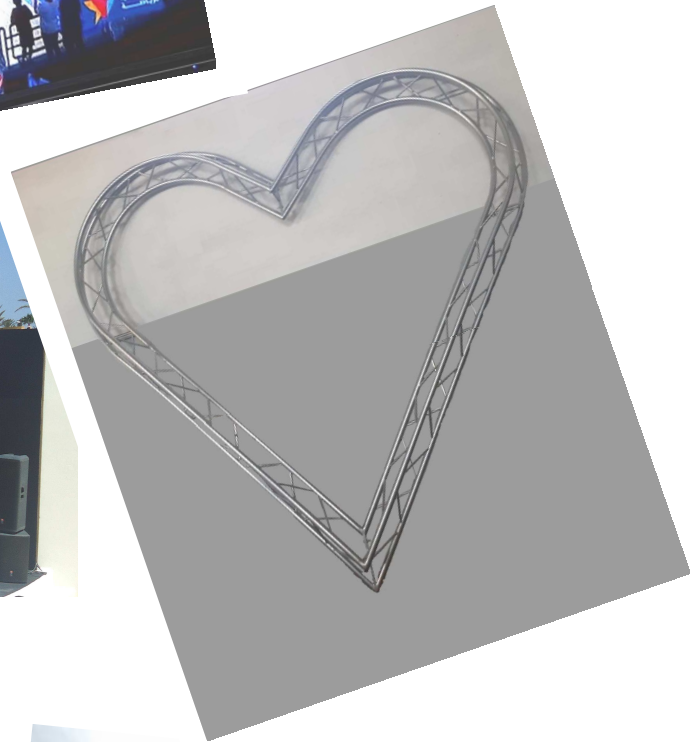
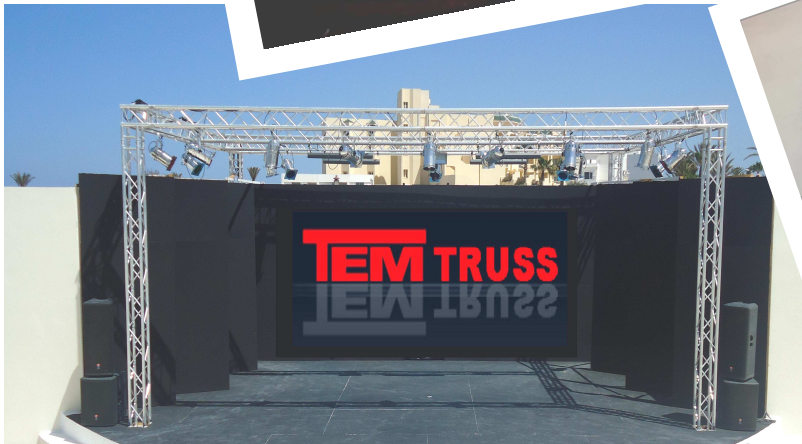





TEM TRUSS

Adresse : Route de Gremda km 9 passage

Teniour 3012 Sfax (Tunisie)

 (+216) 74 65 71 64

 (+216) 74 66 91 76

 (+216) 98 24 21 05

 (+216) 24 483 189

contact@tem-truss.com

 abdelhamid.ghariani@gmail.com

 Tem truss

 www.tem-truss.com